



clawFRplus[®]

DUAL TILT

FLAT ROOF RACKING SPECIALISTS

PanelClaw is the only major racking provider in North America focused exclusively on flat roofs. This specialization provides a competitive advantage for our partners. No one knows more about flat roof racking than PanelClaw; no one delivers a more thoroughly tested and reliable platform; and no one matches our level of service. Our mission is to accelerate the deployment of flat roof PV by continually lowering its life-cycle cost while maintaining the highest levels of reliability. The clawFRplus platform is the result of a 15+ year commitment to flat roof.

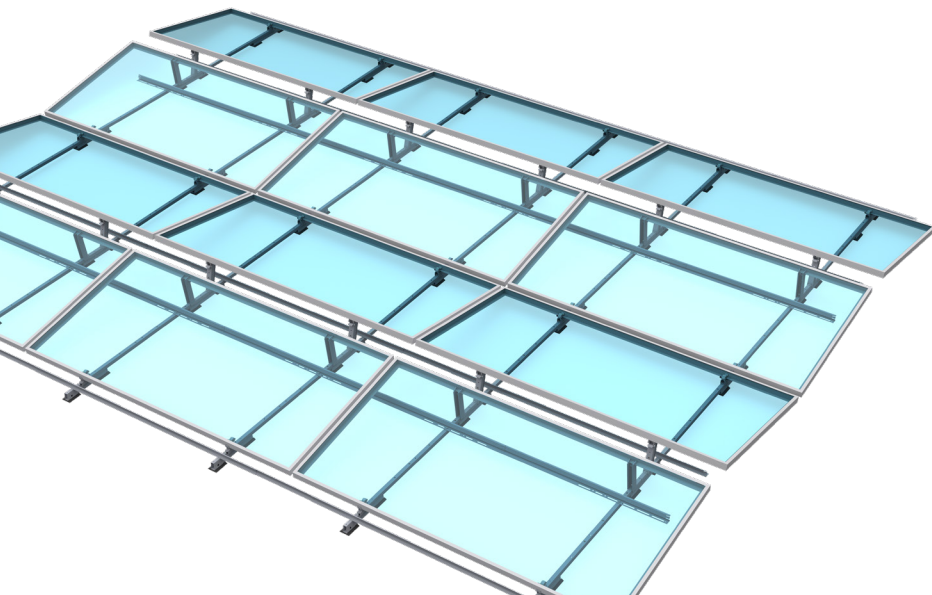

ENGINEERED FOR SPEED

- Single M6 bolt hardware kit
- No-tool module attachment
- 7.8" high side module access gap
- 90 degree single-module tilt-up
- Flexible order of operations installation process allows for optimized coordination of building trades on the roof
- Integrated roof protection pads
- One ground lug required per array

SYSTEM COMPONENTS

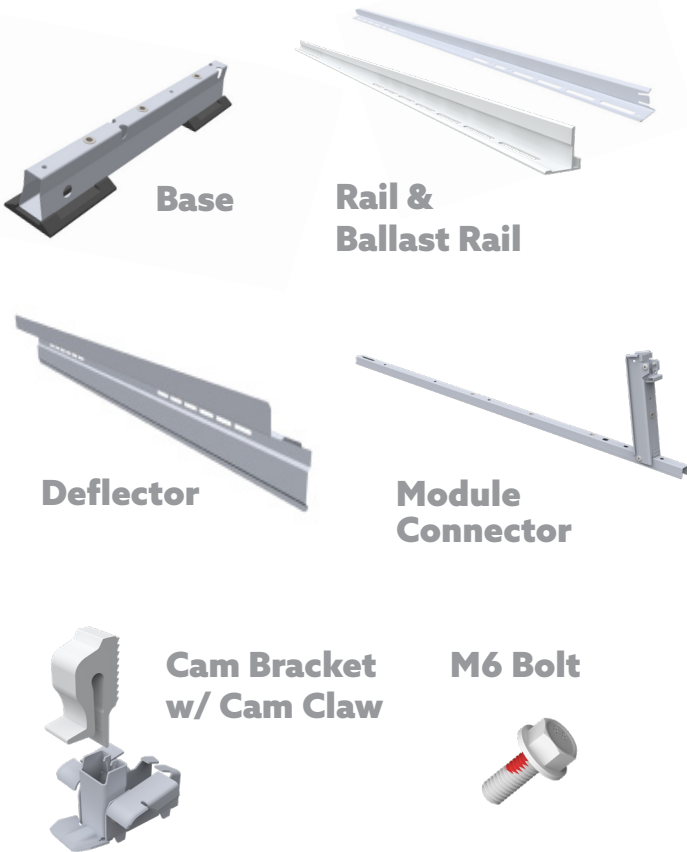

Base

Rail & Ballast Rail

Deflector

Module Connector

Cam Bracket w/ Cam Claw

M6 Bolt

SAFETY & RELIABILITY

clawFRplus™ has undergone a comprehensive suite of reliability and performance tests that exceed US code requirements. Our wind tunnel test program and in-house Intertek® certified satellite test laboratory, supported by third-party peer reviews, collectively form the most comprehensive and robust testing framework in the industry.

PRODUCT DETAILS

APPLICATIONS

< 5° slope flat roofs (up to 7° possible w/engineering review)

BASIC WIND SPEED

Up to 190 mph ASCE 7-16 (>190 mph by approval)

ROOF TYPE COMPATIBILITY

Membrane, tar and gravel, ballasted, BUR, concrete, asphalt (not compatible with metal roofs)

WIND EXPOSURE CATEGORY

B and C (D with review)

USGS SEISMIC CATEGORIES

A, B, C, D (others require engineering review)

PLATFORM LOAD

~ 2.0 ~ 12.0 psf

WARRANTY AND CERTIFICATIONS

25 year warranty
ANSI/UL 2703-2015 Listed
System Fire Rating
Class A with Module Types 1, 2, 16, 19, 22, 25, 29, 30 and 38

MODULE ORIENTATION

Landscape

MODULE ATTACHMENT

Airy point flange mounted

UNIVERSAL TOOL-LESS MODULE CONNECTIONS

clawFRplus™ improves on the industry leading **clawFR** platform. Upgraded high and low side module connections increase system performance and eliminate module adaptor accessories while maintaining **clawFR**'s easy to install architecture.

O&M FEATURES

- Optimizers mount on the Module Connector Tilt Arm, under the module and near the gap between two modules
- ZAM® coating with 3x better corrosion resistance than G90
- Mechanical roof attachments, when needed, are placed in the module row gaps for easy O&M inspection

clawFRplus®
DUAL TILT

