

4

3

↓

2

1

NOTES:
 1. INSTALLATION TO BE COMPLETED IN ACCORDANCE WITH MANUFACTURER'S SPECIFICATIONS.
 2. CONTACT MANUFACTURER FOR DETAILED LAYOUT.

REV	ZONE	DESCRIPTION	APPROVED	DATE

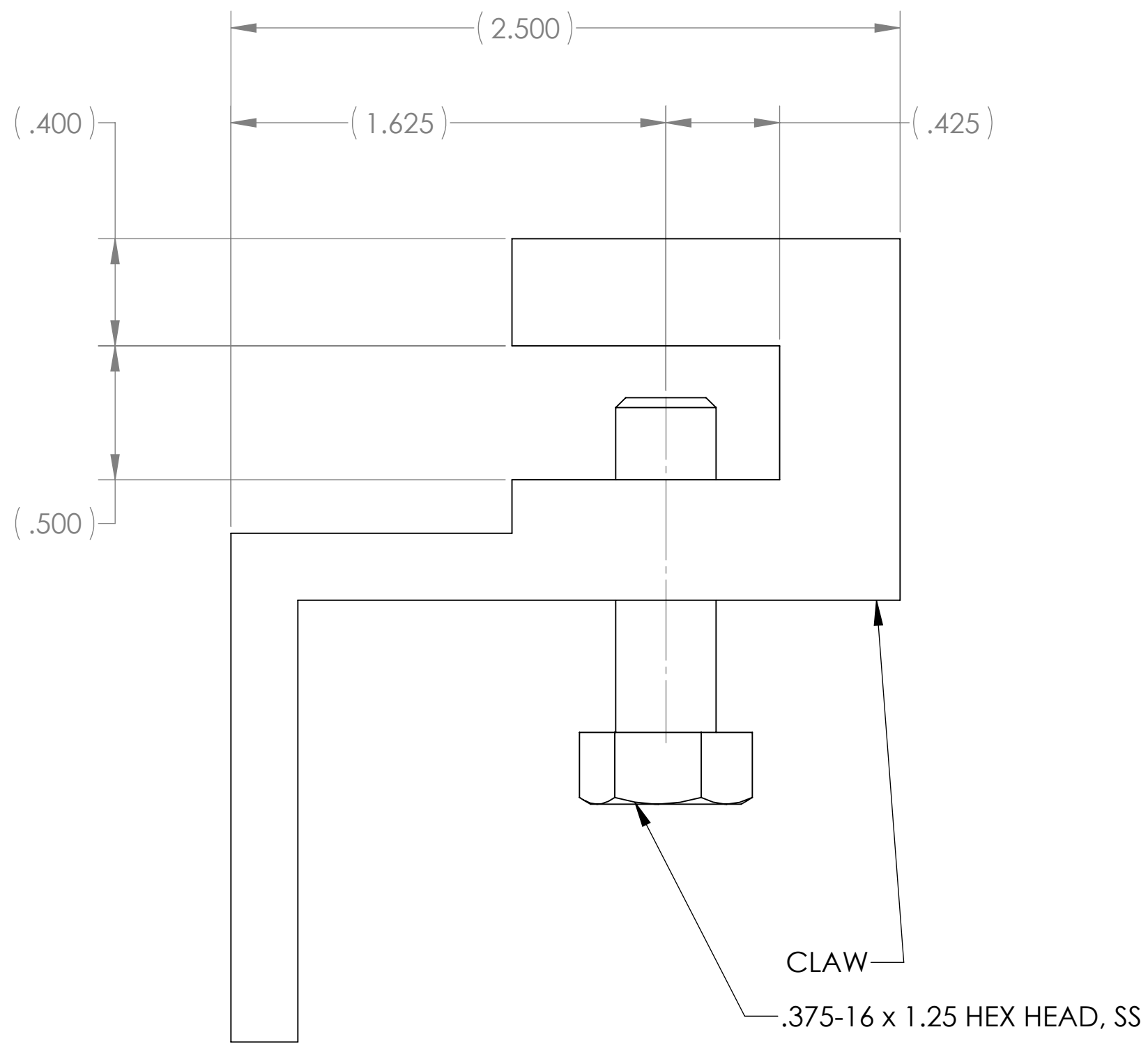
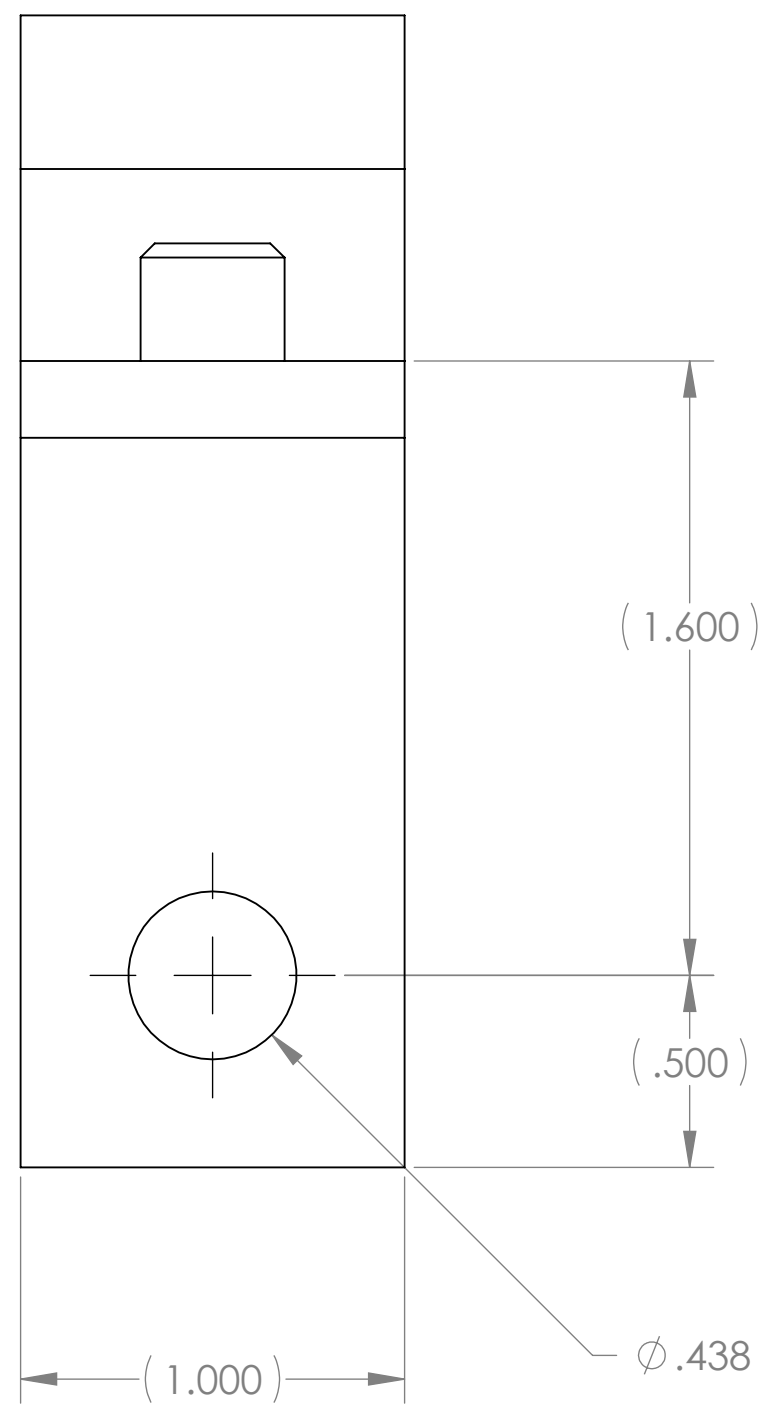

CLAW
 .375-16 x 1.25 HEX HEAD, SS

ALL DIMENSIONS ARE IN INCHES- INTERPRET DRAWING PER ASME Y14.5 -1994

TOLERANCES UNLESS OTHERWISE SPECIFIED:
 X.X ± .03 $\angle \pm .5^\circ$
 X.XX ± .015
 X.XXX ± .005 63/

REMOVE ALL BURRS AND SHARP EDGES .005R OR CHAMFER MAX

APPROVED	DATE
PREP BY D. ANDERSON	9-25-07
CHECKED	
RESP ENG	
MFG ENG	
QUAL ENG	

panel claw

CLAW ASSEMBLY

SIZE C	FSCM NO.	PART NO. CLW001	REV A
SCALE 2:1	WT	LB	SHEET 1 OF 1

4

3

↑

2

1

D

D

C

C

B

B

A

A